

DESIGN NOTES

A Seven Nanosecond Comparator for Single-Supply Operation

Design Note 185

Jim Williams

The LT[®]1394—An Overview

A new ultrahigh speed, single-supply comparator, the LT1394, features TTL-compatible complementary outputs and 7ns response time. Other capabilities include a latch pin and good DC input characteristics (see Figure 1). The LT1394's outputs directly drive all 5V families, including the higher speed ASTTL, FAST and HC parts. Additionally, TTL outputs make the device easier to use in linear circuit applications where ECL output levels are often inconvenient.

A substantial amount of design effort has made the LT1394 relatively easy to use. It is much less prone to oscillation and other vagaries than some slower comparators, even with slow input signals. In particular, the LT1394 is stable in its linear region. Additionally, output-stage switching does not appreciably change power supply current, further enhancing stability. Finally, current consumption is far lower than that of previous devices. These features make the 200GHz gain bandwidth LT1394 considerably easier to apply than other fast comparators.

This device permits fast circuit functions that are difficult or impractical using other approaches. Two applications are presented here.

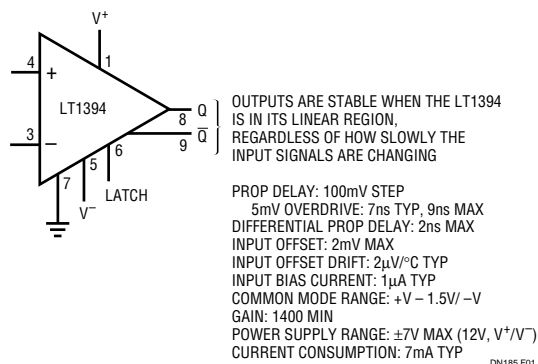

Figure 1. The LT1394 at a Glance

4 \times NTSC Subcarrier Tunable Crystal Oscillator

Figure 2, a variant of a basic crystal oscillator, permits voltage tuning the output frequency. Such voltage-controlled crystal oscillators (VCXO) are often employed where slight variation of a stable carrier is required. This example is specifically intended to provide a 4 \times NTSC subcarrier tunable oscillator suitable for phase locking.

The LT1394 is set up as a crystal oscillator. The varactor diode is biased from the tuning input. The tuning network is arranged so a 0V to 5V drive provides a reasonably symmetric, broad tuning range around the 14.31818MHz center frequency. The indicated selected capacitor sets tuning bandwidth. It should be picked to complement loop response in phase locking applications. Figure 3 is a plot of tuning input voltage frequency deviation. Tuning deviation from the 4 \times NTSC 14.31818MHz center frequency exceeds \pm 240ppm for a 0V to 5V input.

LT, LTC and LT are registered trademarks of Linear Technology Corporation.

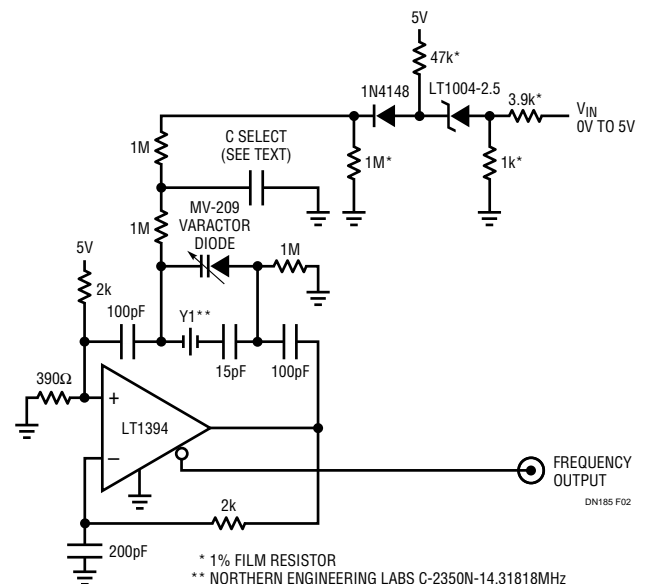

Figure 2. A 4 \times NTSC Subcarrier Voltage-Tunable Crystal Oscillator. Tuning Range and Bandwidth Accommodate a Variety of Phase Locked Loops

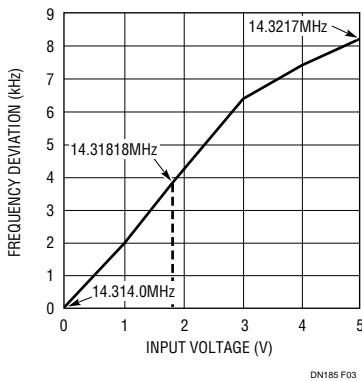

Figure 3. Control Voltage vs Output Frequency for Figure 2. Tuning Deviation from Center Frequency Exceeds ± 240 ppm

High Speed Adaptive Trigger Circuit

Line and fiber-optic receivers often require an adaptive trigger to compensate for variations in signal amplitude and DC offsets. The circuit in Figure 4 triggers on 2mV to 175mV signals from 100Hz to 45MHz while operating from a single 5V rail. A1, operating at a gain of 15, provides wideband AC gain. The output of this stage biases a 2-way peak detector (Q1 through Q4). The maximum peak is stored in Q2's emitter capacitor, while the minimum excursion is retained in Q4's emitter capacitor. The DC value of the midpoint of A1's output signal appears at the junction of the 500pF capacitor and the 3M Ω units. This point always sits midway between the signal's excursions, regardless of absolute amplitude. This signal-adaptive

voltage is buffered by A2 to set the trigger voltage at the LT1394's positive input. The LT1394's negative input is biased directly from A1's output. The LT1394's output, the circuit's output, is unaffected by >85:1 signal amplitude variations. Bandwidth limiting in A1 does not affect triggering because the adaptive trigger threshold varies ratiometrically to maintain circuit output.

Figure 5 shows operating waveforms at 40MHz. Trace A's input produces Trace B's amplified output at A1. The comparator's output is Trace C.

Additional applications and a tutorial on high speed comparator circuitry can be found in Application Note 72, "A Seven Nanosecond Comparator for Single-Supply Operation."

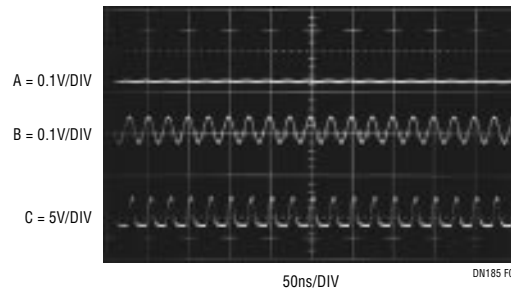

Figure 5. Adaptive Trigger Responding to a 40MHz, 5mV Input. Input Amplitude Variations from 2mV to 175mV are Accommodated

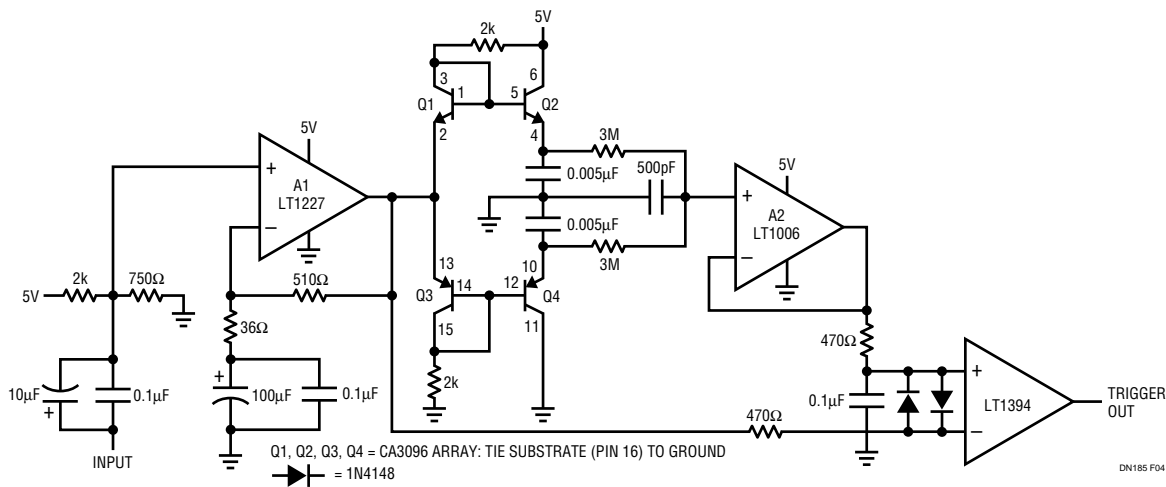

Figure 4. 45MHz Single-Supply Adaptive Trigger. Output Comparator's Threshold Varies Ratiometrically with Input Amplitude, Maintaining Data Integrity over >85:1 Input Amplitude Range

For literature on our High Speed Comparators, call **1-800-4-LINEAR**. For applications help, call (408) 432-1900, Ext. 2456